

MAIN FLOOR

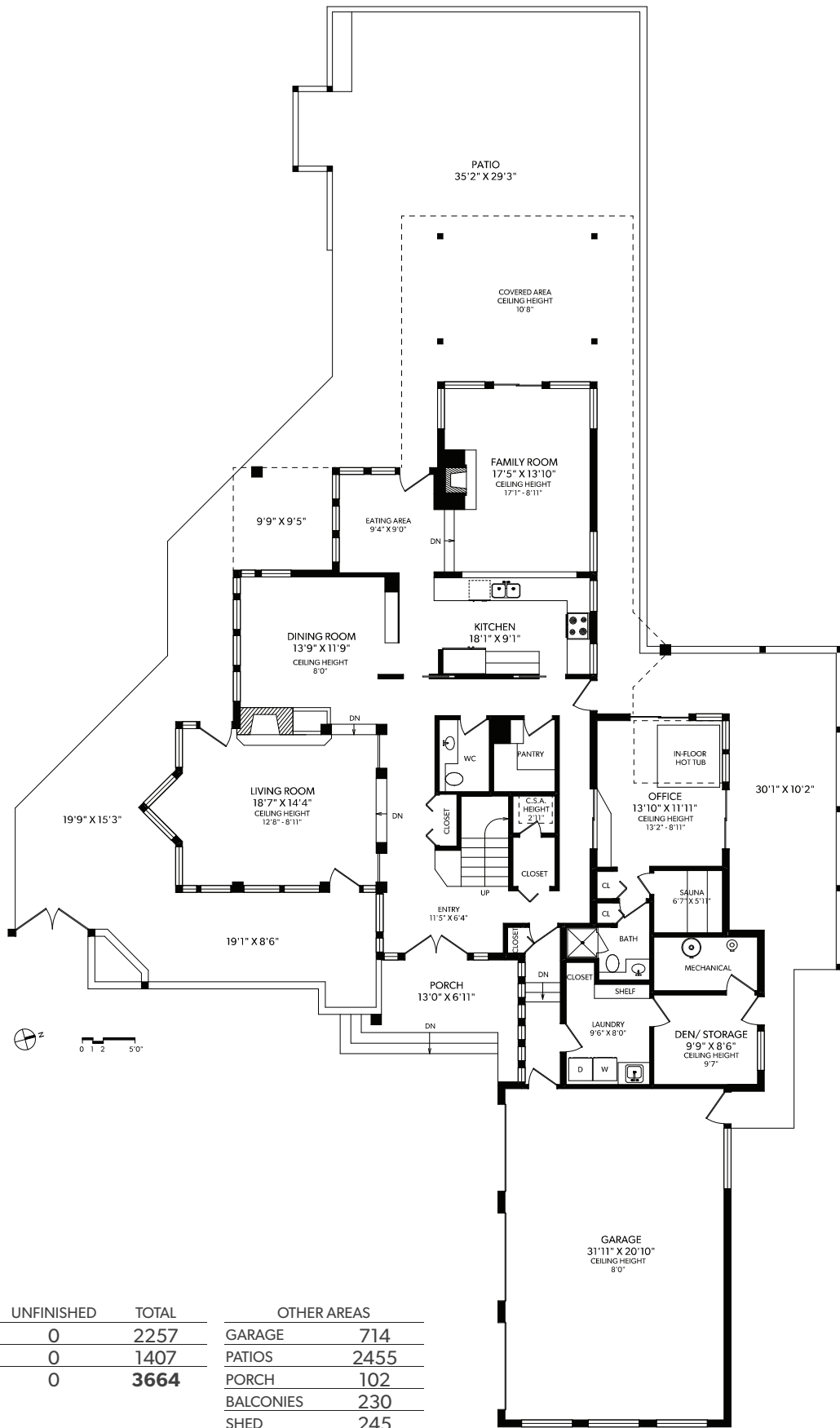

FLOOR	FINISHED	UNFINISHED	TOTAL
MAIN	2257	0	2257
UPPER	1407	0	1407
TOTAL	3664	0	3664

OTHER AREAS	
GARAGE	714
PATIOS	2455
PORCH	102
BALCONIES	230
SHED	245
GAZEBO	149



3120 RIPON ROAD

DOCUMENT PREPARED FOR THE EXCLUSIVE USE OF

TEJ DHALIWAL

250-388-6998
ORDERS@REALFOTO.CA

MEASURED 06/14/2019 BY DAN VAN DER MERWE



All information furnished regarding this property is from sources deemed reliable but no warranty or representation is made to the accuracy thereof. Purchaser to verify measurements if important.

UPPER FLOOR

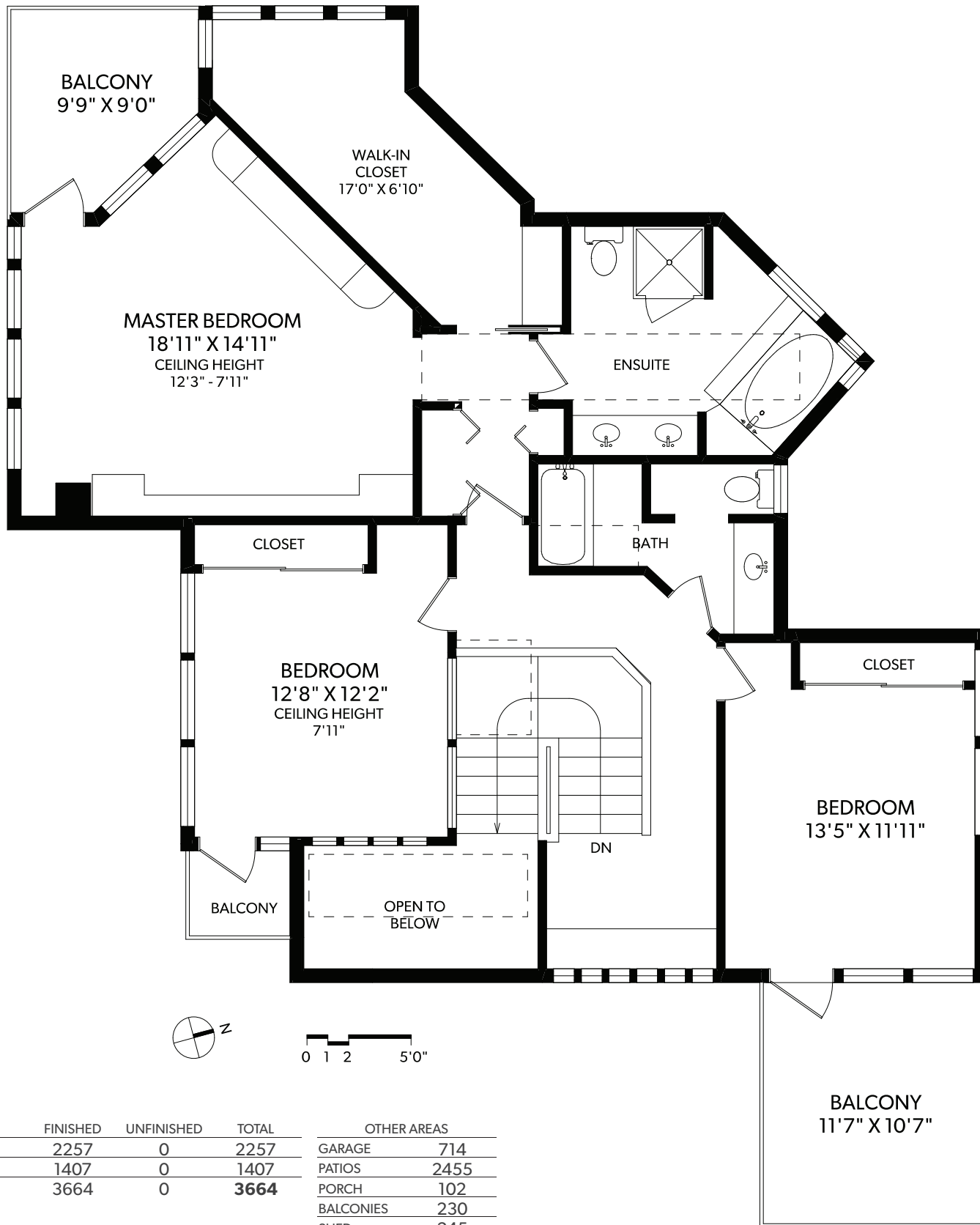

FLOOR	FINISHED	UNFINISHED	TOTAL	OTHER AREAS
MAIN	2257	0	2257	GARAGE 714
UPPER	1407	0	1407	PATIOS 2455
TOTAL	3664	0	3664	PORCH 102
				BALCONIES 230
				SHED 245
				GAZEBO 149



3120 RIPON ROAD

DOCUMENT PREPARED FOR THE EXCLUSIVE USE OF

TEJ DHALIWAL

250-388-6998
ORDERS@REALFOTO.CA

MEASURED 06/14/2019 BY DAN VAN DER MERWE

All information furnished regarding this property is from sources deemed reliable but no warranty or representation is made to the accuracy thereof. Purchaser to verify measurements if important.



OUTBUILDINGS

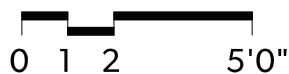
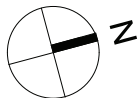
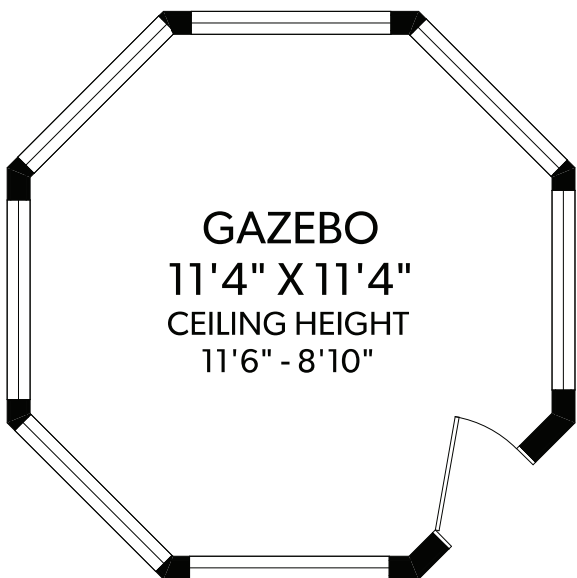
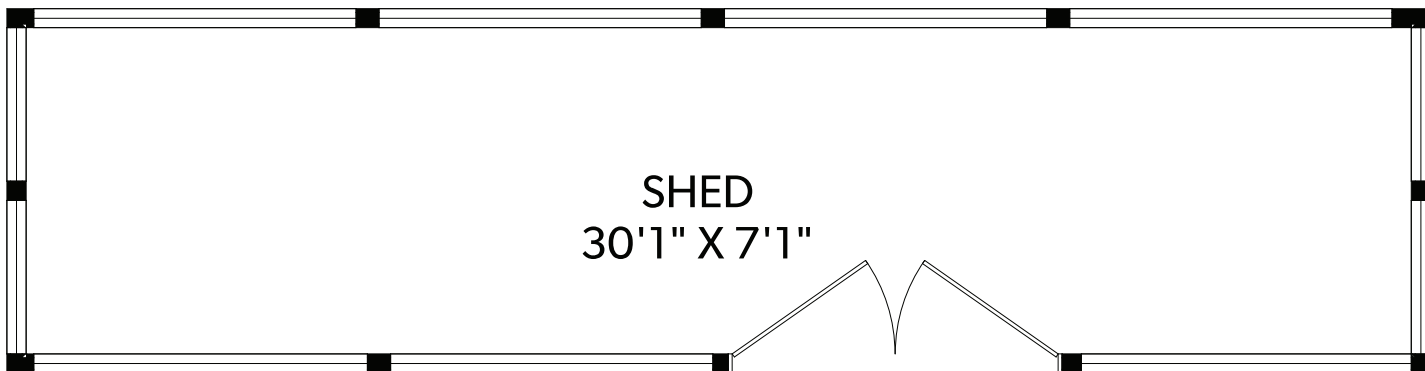

FLOOR	FINISHED	UNFINISHED	TOTAL	OTHER AREAS
MAIN	2257	0	2257	GARAGE 714
UPPER	1407	0	1407	PATIOS 2455
TOTAL	3664	0	3664	PORCH 102
				BALCONIES 230
				SHED 245
				GAZEBO 149



3120 RIPON ROAD

DOCUMENT PREPARED FOR THE EXCLUSIVE USE OF

TEJ DHALIWAL

250-388-6998
ORDERS@REALFOTO.CA

MEASURED 06/14/2019 BY DAN VAN DER MERWE

